

# Packmobile® 4 & Carrier Rack

## *Flexible and Affordable Transport for Large Packages, Boxes and Parts*

- Proven guidepath technology can be installed and changed overnight
- Wide variety of payloads can be accommodated on wire-rack shelves
- Standard batteries and charging system require no special accommodation

As an alternative to conveyor systems, Packmobile can be installed faster, changed easier and operated at lower cost. Useful in mail processing centers, medical labs, check processing centers, clean rooms, remittance processing areas, electronics assembly areas and other locations where light duty transport is needed. Optional carrier racks can accommodate virtually any payload. Trailers can be added to extend capacity.

Packmobile includes full installation and post-installation support from Bell & Howell.



### OPERATIONAL SPECIFICATIONS

#### Guidance

The invisible fluorescent guidepath is applied over existing surfaces and does not usually require structural alteration of your facility. The guidepath is stimulated by ultraviolet light and tracked by photoelectric sensors. Vehicle will not run when it's off the guidepath, except under manual steering. LED bar graph shows quality of guidepath.

#### Programmed Stop

The Packmobile detects either temporary (distribution route) or permanent (end of route) stops, with or without an arrival

tone. Temporary stops can be programmed for 20, 60, or 120 seconds.

#### In-Route Functions

In addition to temporary and permanent stops, standard floor code functions include caution stop, caution light control, radio transmit, volume control and integrated traffic control.

#### Manual Start & Stop

Switches along the top edge of the Packmobile override programmed operation with just a touch.

#### Manual Operation

Top-mounted manual tiller disables programmed operation and allows power-assisted manual operation at a faster pace.

#### Speed

100 feet per minute.

#### Operating Cycle

10 hours at full charge over level surface.

#### Operating Power

24 VDC from two 12VDC maintenance-free gel electrolyte batteries (90 AH at 9 hr rating). Typical recharge: 8 hrs, using 2.4 kwh/day. LED bar graph shows state of charge. UL listed.

#### Battery Charger

600 watt internal charger with retractable cord and overcharge prevention. Plugs into any standard 115 volt, 60 Hz, 15 amp receptacle.

#### Upgrade Kits (optional)

**Branching/Routing** — Allows stops, in-route functions and sophisticated routes to be programmed into the Packmobile's memory rather than simply on the guidepath to allow user-defined changes to be made easily.

**Pathless Travel** — Allows Packmobile to travel without the guidepath for about 15 feet.



**BELL+HOWELL**

Mailmobile

11818 James Street • Holland, MI 49424-9674  
1-616-393-0101 FAX 616-393-6163  
www.mailmobile.com



## Site Requirements

Site alterations are usually not required. Here are the recommended minimum turning clearances:

IF AISLE "A" IS	AND A "TYPE 1" TURN IS DESIRED THEN AISLE "B" MUST BE AT LEAST	AND A "TYPE 2" TURN IS DESIRED THEN AISLE "C" MUST BE
INCHES WIDE	INCHES WIDE	INCHES WIDE
32	56	56
36	52	52
40	50	50
44	48	48
48	45	46
52	42	44
56	41	43
60	40	42
64	38	41
68	37	40
72	36	39
76	35	38 1/2
80	34	38
84	33	38
88	32 1/2	38
92	32	37 1/2
96	31 1/2	37 1/2
108	30	36
120	28	36

D=76" minimum to allow for U-TURN

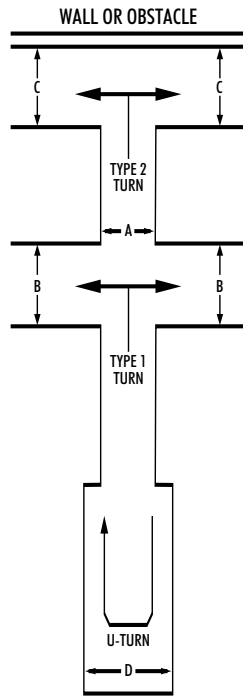

### FLOOR VARIATION:

- Maximum ramp is 8 percent.
- Maximum vertical step is 0.25".

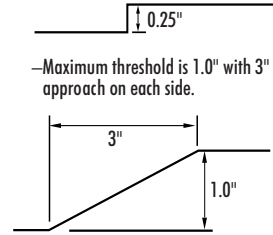

- Maximum threshold is 1.0" with 3" ramp approach on each side.

## PHYSICAL CHARACTERISTICS

### Overall Dimensions Packmobile 4

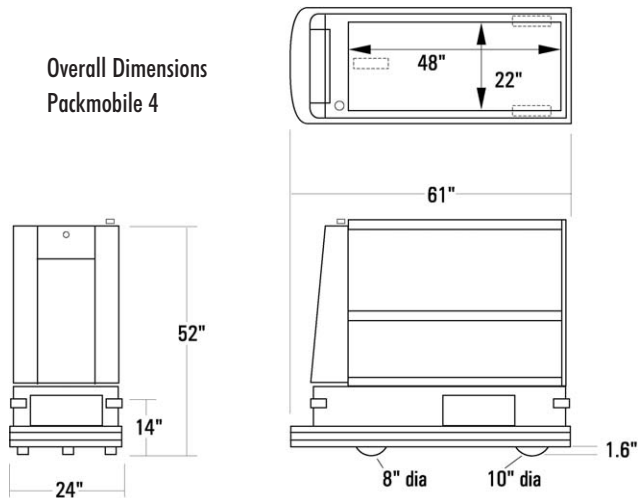

### Carrier Racks (optional)

- 48" x 21" wire shelves with 1-inch ledge
- Adjustable in 1" increments
- 3 Shelf: 34" H
- 5 Shelf: 54" H

### Operating Signals

Intermittent "beep" tone during travel.  
Warning tone prior to movement. Volume control. Running lights flash during travel.

### Obstacle Detection (Noncontact)

Front-focused limited radio field (800 Khz, 2.8 mW typical) detects objects, triggering stop. Will not start until object is removed from path. Typical adjustment range 2"-24".

### Obstacle Detection (Contact)

Pressure activation. Locations: front bumper, side bumper, vertical bumper (front carrier corners), toe switch (bottom of chassis). Obstacle detection stops vehicle.

### Weight

568 lbs.

### Construction

Aluminum with off-white powder coat finish.

### Capacity

1000 lbs. on level surfaces; UL tested.  
400 lbs. on 8% slope; UL tested.

### Wheel Load

Empty: 288 lbs. front, 155 lbs. r. rear, 125 lbs. l. rear. (100 psi, max).  
325 lb. Payload: 462 lbs. front, 231 lbs. r. rear, 200 lbs. l. rear. (125 psi, max).  
800 lb. Payload: 720 lbs. front, 339 lbs. r. rear, 309 lbs. l. rear. (200 psi, max).

### Towing

Drawbar pull 75 lbs. typical, 125 lbs. max.  
Tows up to 1800 lbs. on level surfaces with specially designed Bell & Howell trailers.

Total Combined Payload 2,800 lbs.