

Mailmobile® 4 The Newest Generation

*This Sleek Design Offers Expanded Features
For Automated Information Delivery.*

- Manual Tiller with Electronically-Powered Steering and Traction
- 34-Function Programmable Capability
- Reads More Guidepath Codes
- Independent Reverse and Slow-Speed Modes
- Many Other Features

Now time-sensitive internal information delivery enters the 21st century with Mailmobile 4. This design builds on the strengths of Bell & Howell's proven Mailmobile technology that has internal mail delivery on the right track across North America. Mailmobile 4 has the features customers have asked for, providing even more convenience and efficiency to internal delivery.

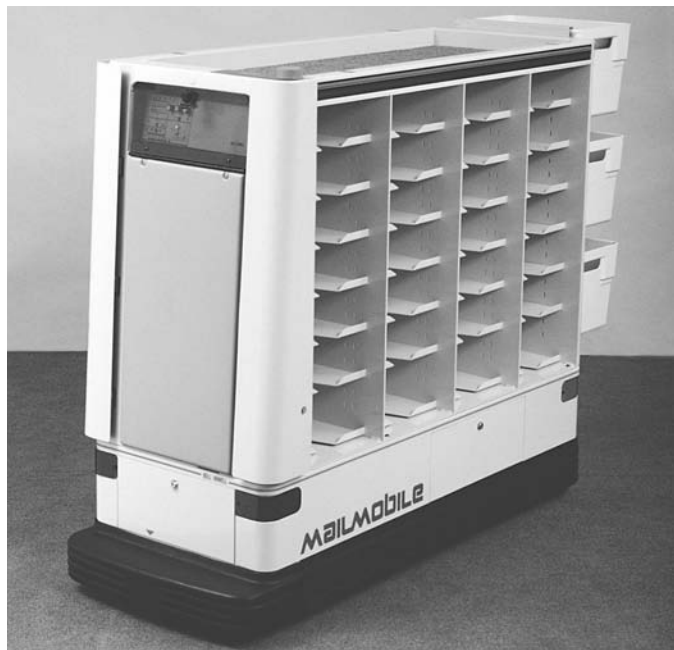

OPERATIONAL SPECIFICATIONS

Guidance

The invisible fluorescent guidepath is applied over existing surfaces and does not usually require structural alteration of your facility. The guidepath is stimulated by ultraviolet light and tracked by photoelectric sensors. Vehicle will not run when it's off the guidepath, except under manual steering. LED bar graph shows quality of guidepath.

Programmed Stop

The Mailmobile detects either temporary (distribution route) or permanent (end of route) stops, with or without an arrival

tone. Temporary stops can be programmed for 20, 60, or 120 seconds.

In-Route Functions

In addition to temporary and permanent stops, standard floor code functions include caution stop, caution light control, radio transmit, volume control and integrated traffic control.

Manual Start & Stop

Switches along the top edge of the Mailmobile override programmed operation with just a touch.

Manual Operation

Top-mounted manual tiller disables programmed operation and allows power-assisted manual operation at a faster pace.

Speed

100 feet per minute.

Operating Cycle

10 hours at full charge over level surface.

Operating Power

24 VDC from two 12VDC maintenance-free lead-acid batteries. Typical recharge: 8 hrs, using 2.4 kwh/day. LED bar graph shows state of charge. UL listed.

Battery Charger

600 watt internal charger with retractable cord and overcharge prevention. Plugs into any standard 115 volt, 60 Hz, 15 amp receptacle.

Upgrade Kit (optional)

Allows stops, in-route functions and sophisticated routes to be programmed into the Mailmobile's memory rather than simply on the guidepath to allow user-defined changes to be made easily, as well as allowing the Mailmobile to travel without the guidepath for about 15 feet. Used primarily for exiting elevators.

egemin
AUTOMATION

BELL+HOWELL

Mailmobile

11818 James Street • Holland, MI 49424-9674
1-616-393-0101 FAX 616-393-6163
www.mailmobile.com



Site Requirements

Site alterations are usually not required. Here are the recommended minimum turning clearances:

IF AISLE "A" IS	AND A "TYPE 1" TURN IS DESIRED THEN AISLE "B" MUST BE AT LEAST	AND A "TYPE 2" TURN IS DESIRED THEN AISLE "C" MUST BE
INCHES WIDE	INCHES WIDE	INCHES WIDE
32	56	56
36	52	52
40	50	50
44	48	48
48	45	46
52	42	44
56	41	43
60	40	42
64	38	41
68	37	40
72	36	39
76	35	38 1/2
80	34	38
84	33	38
88	32 1/2	38
92	32	37 1/2
96	31 1/2	37 1/2
108	30	36
120	28	36

D = 76" minimum to allow for U-TURN

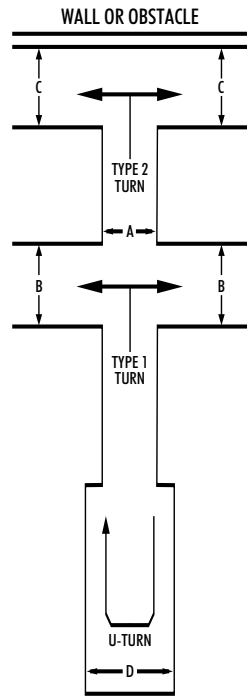

FLOOR VARIATION:

- Maximum ramp is 8 percent.
- Maximum vertical step is 0.25".
- Maximum threshold is 1.0" with 3" ramp approach on each side.

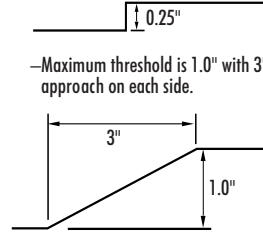

PHYSICAL CHARACTERISTICS

Overall Dimensions Mailmobile 4

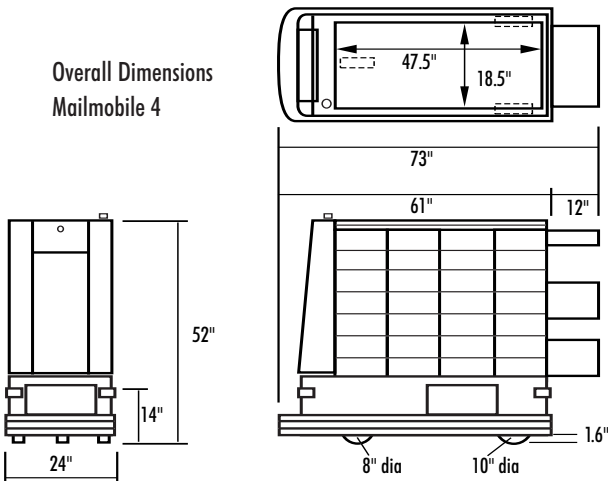

Carrier

Divided into four bays with access from both sides and top tray. Plastic ABS shelves (11 1/2" L x 18" W) fit into bays, adjust in 1 1/2" increments, and include tabs for labeling. 28 shelves provided; maximum standard shelves 44 at 3" spacing. Three rear-mount containers provided.

Operating Signals

Intermittent "beep" tone during travel. Warning tone prior to movement. Volume control. Running lights flash during travel.

Obstacle Detection (Noncontact)

Front-focused limited radio field (800 Khz, 2.8 mW typical) detects objects, triggering stop. Will not start until object is removed from path. Typical adjustment range 2"-24".

Obstacle Detection (Contact)

Pressure activation. Locations: front bumper, side bumper, vertical bumper (front carrier corners), toe switch (bottom of chassis). Obstacle detection stops vehicle.

Weight

590 lbs.

Construction

Aluminum carrier, steel chassis with off-white powder coat finish.

Capacity

800 lbs. on level surfaces.
400 lbs. on 8% slope.

Wheel Load

Empty: 288 lbs. front, 155 lbs. r. rear, 125 lbs. l. rear. (100 psi, max).
325 lb. Payload: 462 lbs. front, 231 lbs. r. rear, 200 lbs. l. rear. (125 psi, max).
800 lb. Payload: 720 lbs. front, 339 lbs. r. rear, 309 lbs. l. rear. (200 psi, max).

Towing

Drawbar pull 75 lbs. typical, 125 lbs. max.
Tows up to 1800 lbs. on level surfaces with specially designed Bell & Howell trailers.